



thermal transfer overprinters *communicator II*

*Maximum
uptime and
minimum
consumable costs
in both intermittent
and continuous
applications*

EASYPRINT specialises in thermal transfer printing technology. The ideal solution when printing onto polyethylene, polypropylene, paper, labels, tyvek and other flexibles.

Thermal transfer overprinting is clean, durable and low maintenance, enabling printing of variable text, logos and bar codes in 300 dpi resolution and a wide range of colors.

EASYPRINT provides a comprehensive range of high-speed thermal transfer coders and printers for integration in intermittent / continuous motion vertical and horizontal form, fill & seal machinery, thermal forming machines and labellers.

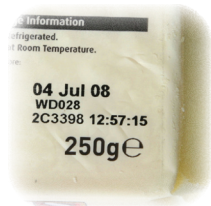

Maximum uptime and throughput

- Industry leading ribbon length of 1400 metre offers up to 40% longer uptime than competition
- COMMUNICATOR II's unique ribbon control prevents costly downtime caused by ribbon breakage and ensures responsiveness at high speed
- 5 inch (128 mm) model allows COMMUNICATOR II to meet even the most demanding requirements

Lowest cost per print and best total OEE^{*)}

- Patented variable ribbon economy function reduces cost per print by up to 60% compared to competition, in both intermittent and continuous mode
- Ribbon retraction of less than 1 mm between messages minimises consumable usage

Intelligence moved to the printer

- Built-in intelligence eliminates the need for a controller. Printer can be controlled from existing OEM user interface, PC browser or optional colour touchscreen
- Intermittent and continuous in same printer, changed directly through software
- Easy onboard label creation software eliminates the need for costly software
- Remote management through ethernet for optimal monitoring and control



COMMUNICATOR II mounted in the high-quality window bracket.

The optional 10.4" colour touch screen displays realtime status, warning and remaining ribbon

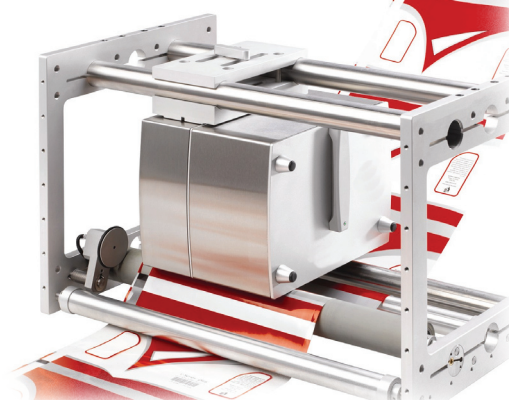

^{*)} Overall Equipment Efficiency.
For a calculation of cost of ownership, please contact your sales representative

Specifications *communicator II*

	COMMUNICATOR II - 2"	COMMUNICATOR II - 5"
Printer Unit		
Weight and dimensions	12 kg 260(W) x 190(H) x 225(D)	14 kg 260(W) x 190(H) x 305(D)
Print density	300 dpi	300 dpi
Print speed	Up to 1400 mm / second in continuous mode *) Up to 5 prints per second in intermittent mode (53 x 25 mm area) *) *) Dependent on message size, substrate, ambient temperature, installation quality and ribbon used	
Print area (intermittent)	53 x 115 mm	128 x 115 mm
Print area (continuous)	53 x 2700 mm	128 x 1000 mm
Character control	Real time clocks, text (true type fonts), logos, bar codes and graphics	
Ribbon System		
Ribbon length	up to 1400 metre	up to 1400 metre
Ribbon width	25 - 55 mm	25 - 130 mm
Ribbon saving	Fully adjustable ribbon economy (1-60%) in both intermittent and continuous mode. Works on text, graphics and barcodes. Ribbon retraction feature with less than 1mm between messages	
Controller		
User interface	Web browsable graphical user interface (GUI) or dedicated browser software Optional EASYPRINT touchscreen available with 10,4" full colour	
Label creation	Full on board capability, EasyDesign PC application or through Firefox 2+/ IE browser. Drivers for CodeSoft, labelview, prisym and Windows available	
Optional Touch Screen	10.4" SVGA full colour, designed to IP 65 310(W) x 235(H) x 80(D)	
Features		
Connectivity	Ethernet, USB (for USB-stick), Secure Digital (on printer only), Digital I/O for host machine integration.	
Alarm outputs	Low ribbon warning, ribbon end and other general fault conditions	
IP rating	Designed to IP44 (when printhead opening is covered)	
Accessories	Full range of bracketry	
Approvals	CE	
Environment		
Installation	Temperature 5 – 40 °C Humidity 10 – 80 % without condensation	
Electrical	115/230 VAC, 50/60 HZ, 300VA	
Air supply	10 LT/min @ 6 bar max - clean air	

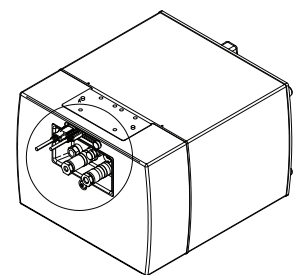
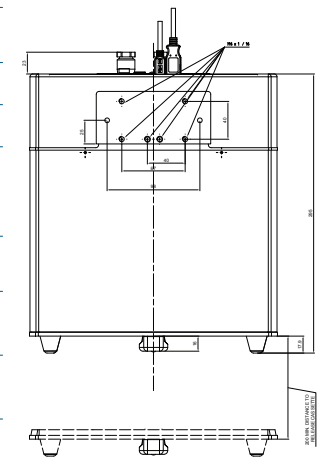
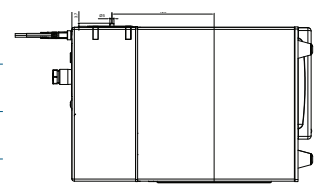
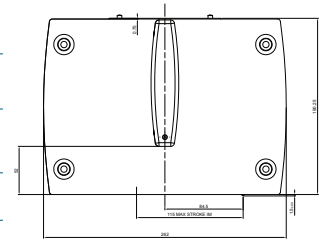

5" (128 mm) left hand model shown.

Also available in 2" (53 mm) and right hand version

Your partner:



EASYPRINT AUSTRALIA PTY LTD
 27 Cleg Street
 ARTARMON NSW 2064
 Phone: 02 9439 9555
 Fax: 02 9439 9556
www.easy-print.com.au

EASYPRINT A/S
 Bredebjergvej 1, 1.sal
 DK-2630 Taastrup
 Denmark

Tel: +45 46 15 41 40
 Fax: +45 46 15 41 70
www.easy-print.com

